

Mining Excavator

R 9350

Operating Weight with Backhoe Attachment:	302,000 kg / 665,800 lb
with Shovel Attachment:	310,000 kg / 683,400 lb
Engine Output:	1120 kW / 1500 hp
Bucket Capacity:	15,30 – 18,00 m ³ / 20.0 – 23.5 yd ³
Shovel Capacity:	15,30 – 18,00 m ³ / 20.0 – 23.5 yd ³



LIEBHERR

Technical Data



Engine

1 Cummins diesel engine	
Rating per SAE J 1995	1500 hp (1120 kW) at 1800 rpm
Model	QSK45
Type	12 cylinder turbocharged V-engine after-cooler
	two separate water cooling circuits direct injection system
Displacement	45 l/2745 in ³
Bore/Stroke	159/190 mm / 6.26/7.48 in
Engine cooling system	fans driven via hydraulic piston motor
Air cleaner	dry-type air cleaner with pre-cleaner, with automatic dust ejector, primary and safety elements
Fuel tank	5815 l/1536 gal
Electrical system	
Voltage	24 V
Batteries	4 (+ 2) x 170 Ah/12 V
Alternator	24 V/260 Amp
Engine idling	sensor controlled
Electronic engine control system	engine speed sensing over the entire engine RPM range. Provides integration of engine with other machine systems



Hydraulic System

Hydraulic pumps for attachment and travel drive	4 variable flow axial piston pumps
Max. flow	4 x 754 l/min. / 4 x 199 gpm
Max. hydr. pressure	320 bar/4,640 psi
Hydraulic pump for swing drive	2 reversible swash plate pumps, closed-loop circuit
Max. flow	2 x 390 l/min. / 2 x 103 gpm
Max. hydr. pressure	350 bar/5,076 psi
Pump regulation	electro-hydraulic pressure compensation flow compensation automatic oil flow optimizer
Hydraulic tank capacity	2200 l/581 gal
Hydraulic system capacity	4200 l/1110 gal
Hydraulic oil filter	filtration of entire return flow, 1 high pressure filter for each main pump
Hydraulic oil cooler	2 separate coolers, 2 temperature controlled fans driven via hydraulic piston motor



Hydraulic Controls

Servo circuit	independent, electric over hydraulic proportional controls of each function
Emergency control	via accumulator for all attachment functions with stopped engine
Power distribution	via monoblock control valves with integrated primary relief valves and flanged on secondary valves
Flow summation	to attachment and travel drive
Control functions	
Attachment and swing	proportional via joystick levers
Travel	proportional via foot pedals or hand levers
Bottom dump bucket	proportional via foot pedals



Swing Drive

Hydraulic motor	2 Liebherr axial piston motors
Swing gear	2 Liebherr planetary reduction gears
Swing ring	Liebherr, sealed triple roller swing ring, internal teeth
Swing speed	0-3.7 rpm
Swing torque	1120 kNm/82,607 lbf ft
Swing-Holding brake	hydraulically released, maintenance-free, multi-disc brakes integrated in each swing gear



Uppercarriage

Design	torque resistant designed upper frame in box type construction for superior strength and durability
Attachment mounting	parallel longitudinal main girders in box-section construction
Catwalks	on the left side with a hydraulically driven access ladder, catwalks in front of the pumps and in the counterweight, additional emergency ladder in front of the cab



Service Flap

Design	hydraulically actuated service flap, with lighting easily accessible from ground level to allow: <ul style="list-style-type: none">- fuel fast refill- hydraulic oil refill- engine oil quick change- splitterbox oil quick change- swing gearbox oil quick change- swing ring teeth grease barrel refilling via grease filter- attachment/swing ring bearing grease barrel refilling via grease filter- windshield wash water refilling
Quick couplers	on request

Technical Data



Operator's Cab

Design	resiliently mounted, sound insulated, large windows for all around visibility, integrated falling object protection FOPS
Operator's seat	suspended, body-contoured with shock absorber, adjustable to operator's weight
Cabin windows	20,5 mm/0.8 in tinted armored glass for front window and right hand side windows, all other windows in tinted safety glass, high pressure windshield-washer system 75 l/20 gal watertank, steel sun louvers on all windows
Heating system/ Air conditioning	1 heating system + air conditioning (double unit optionally available)
Cabin pressurization	ventilation with filter
Controls	joystick levers integrated into armrest of seat
Monitoring	via LCD-Display, data memory
Automatic engine shut off	engine self-controlled shut off
Destroking of main pumps	in case of low hydraulic oil level
Safety functions	additional gauges with constant display for: engine speed, hourmeter, voltmeter, safety mode for engine speed control and pump regulation
Noise emission ISO 6396	L_{pA} (inside cab) = 89 dB(A) with AC/heater 100 % running fans



Undercarriage

Design	3-piece undercarriage, box type structures for center piece and side frames (stress relieved steel work component as a standard)
Hydraulic motor	2 axial piston motors per side frame
Travel gear	Liebherr planetary reduction gear
Travel speed	0-2,4-3,1 km/h / 0-1.49-1.93 mph
Parking brake	spring engaged, hydraulically pressure released wet multi-disc brakes for each travel motor, maintenance-free
Track components	D 12, maintenance-free, forged double grouser pad
Track rollers/ Carrier rollers	9/2
Automatic track tensioner	pressurized hydraulic cylinder with accumulator
Transport	undercarriage side frames are removable



Central Lubrication System

Type	Lincoln Centromatic lubrication system, for the entire attachment and swing ring
Grease pumps	Lincoln Powermaster pump plus separate pump for swing ring teeth
Capacity	200 l/53 gal bulk container for attachment and swing ring, separated 80 l/21 gal grease drum for swing ring teeth
Refill	via the service flap for both containers. Fill line with grease filters



Attachment

Design	box-type structure with large steel castings in all high-stress areas
Pivots	sealed with double side centering with 1 single floating pin per side, all bearings with wear resistant steel bushings, bolts hardened and chromium-plated
Hydraulic cylinder	Liebherr design, all cylinders located in well protected areas
Hydraulic connections	pipes and hoses equipped with SAE split-flange connections
Kinematics	Liebherr parallel face shovel attachment geometry, backhoe bucket pivoting angle 150°, electronic controlled end-cushioning

Dimensions

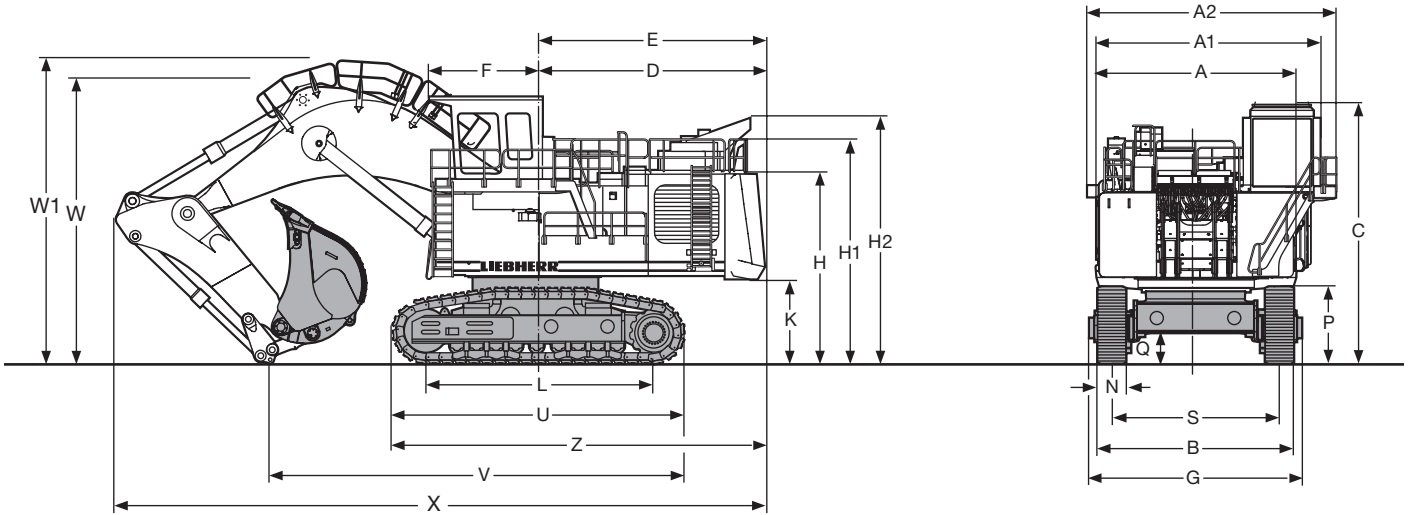

	mm/ft in
A	5800/19'
A1	6720/22' 1"
A2	7400/24' 3"
C	7800/25' 7"
D	6395/20'12"
E	6395/20'12"
F	3100/10' 2"
H	5480/17'12"
H1	6500/21' 4"
H2	7075/23' 3"
K	2280/ 7' 6"
L	6400/21'

	mm/ft in
P	2360/ 7' 9"
Q	982/ 3' 3"
S	5000/16' 5"
U	8334/27' 4"
Z	10470/34' 4"
N	850/ 2' 9"
B	5850/19' 2"
G	6340/20'10"
V	11800/38' 9"
W	8100/26' 7"
W1	8700/28' 7"
X	18450/60' 6"

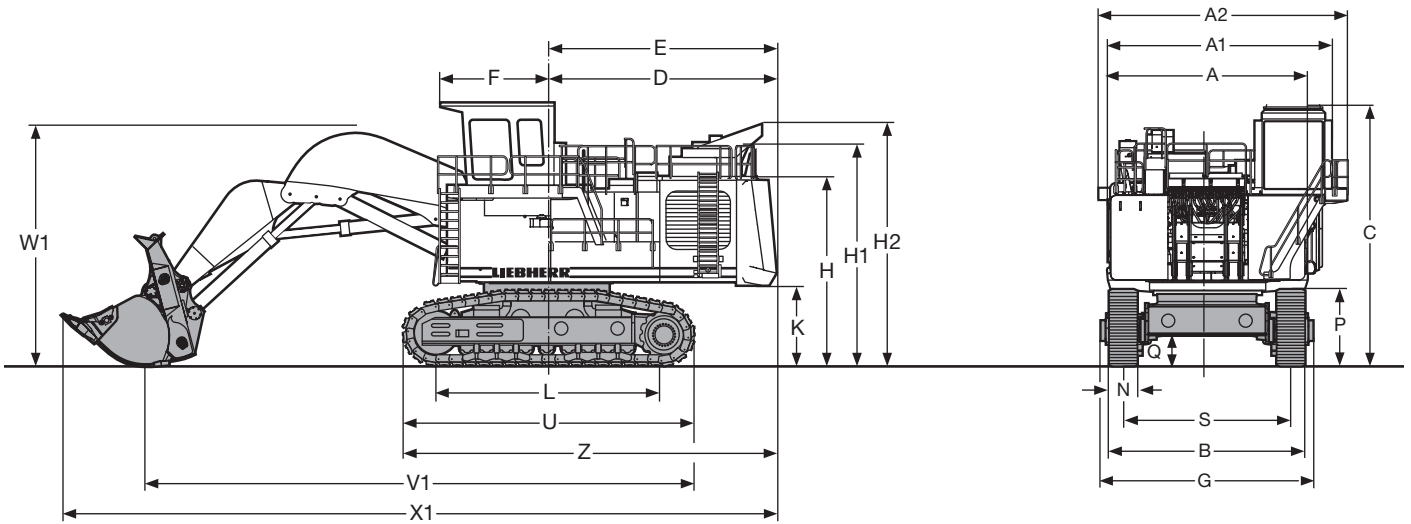

	mm/ft in
A	5800/19'
A1	6720/22' 1"
A2	7400/24' 3"
C	7800/25' 7"
D	6395/20'12"
E	6395/20'12"
F	3100/10' 2"
H	5480/17'12"
H1	6500/21' 4"
H2	7075/23' 3"
K	2280/ 7' 6"
L	6400/21'

	mm/ft in
P	2360/ 7' 9"
Q	982/ 3' 3"
S	5000/16' 5"
U	8334/27' 4"
Z	10470/34' 4"
N	850/ 2' 9"
B	5850/19' 2"
G	6340/20'10"
V1	15900/52'20"
W1	7100/23' 4"
X1	20700/67'11"

Backhoe Attachment

with Gooseneck Boom 9,30 m/30'6" and Stick 4,20 m/13'8"

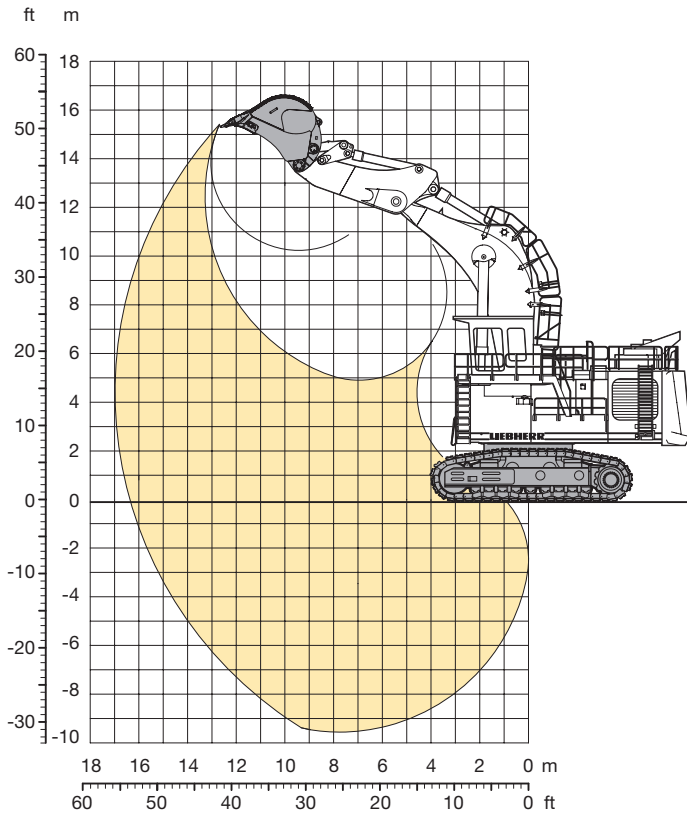

Digging Envelope

Max. reach at ground level	16,30 m/53'6"
Max. teeth height	15,40 m/50'6"
Max. dump height	10,20 m/33'6"
Max. digging depth	9,50 m/31'2"
Max. digging force	880 kN (89,7 t)/197,832 lbf (197,750 lb)
Max. breakout force	1020 kN (104,0 t)/229,305 lbf (229,280 lb)

Operating Weight and Ground Pressure

The operating weight includes the basic machine with backhoe attachment and a 18,00 m³/23.5 yd³ bucket.

Pad width	mm/in	850/34
Weight	kg/lb	302000/665,800
Ground pressure	kg/cm ² /psi	2,51/35.27

Bucket

Cutting width SAE	mm/in	3400/134 ¹⁾	3400/134 ¹⁾	3400/134 ¹⁾
Capacity SAE heaped	m ³ /yd ³	15,30/20	17,00/22.2	18,00/23.5
Weight	kg/lb	17000/37,480	17790/39,220	18155/40,020
Suitable for material up to a specific weight of	t/m ³ /lb/yd ³	2,10/3,570	1,90/3,230	1,80/3,000
Wear kit level		II	II	II

¹⁾ Bucket with delta cutting edge and tooth system Posilok size S 95.

Wear kit level II: For heavy rock, not deteriorated or cracked. Has to be shot to be dug.

Additional buckets on request.

Shovel Attachment

with Shovel Boom 6,75 m/22'2" and Stick 4,20 m/13'8"

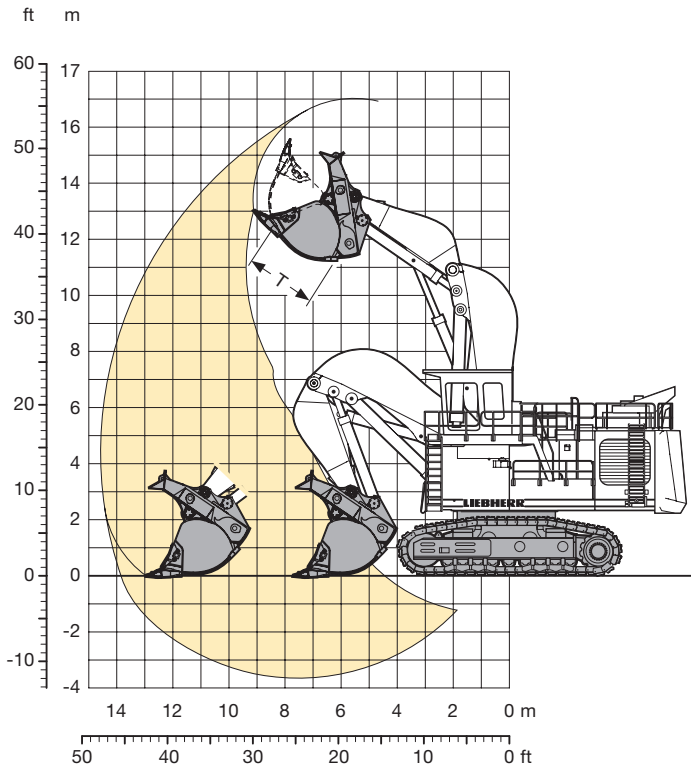

Digging Envelope

Max. reach at ground level	13,75 m/45'1"
Max. dump height	11,20 m/36'9"
Max. crowd length	5,20 m/17'1"
Bucket opening width T	2500 mm/98"
Crowd force at ground level	1040 kN (106,0 t)/233,801 lbf (233,690 lb)
Max. crowd force	1300 kN (132,5 t)/292,252 lbf (292,110 lb)
Max. breakout force	1060 kN (108,0 t)/238,297 lbf (238,100 lb)

Operating Weight and Ground Pressure

The operating weight includes the basic machine with shovel attachment and a 18,00 m³/23.5 yd³ bucket.

Pad width	mm/in	850/34
Weight	kg/lb	31000/683,400
Ground pressure	kg/cm ² /psi	2,58/36.69

Bottom Dump Bucket

Cutting width SAE	mm/in	4100/161 ¹⁾	4100/161 ¹⁾	4100/161 ¹⁾
Capacity SAE heaped	m ³ /yd ³	15,30/20	17,00/22.2	18,00/23.5
Weight	kg/lb	30000/66,140	31000/68,340	31500/69,450
Suitable for material up to a specific weight of	t/m ³ /lb/yd ³	2,10/3,570	1,90/3,230	1,80/3,000
Wear kit level		II	II	II

¹⁾ Bottom dump bucket with delta cutting edge and tooth system Posilok size S 95.
Wear kit level II: For heavy rock, not deteriorated or cracked. Has to be shot to be dug.

Additional bottom dump buckets on request.

Component Dimensions and Weights

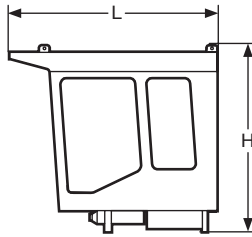

Cab

L Length	mm/ft in	3600/11'10"
H Height	mm/ft in	2900/ 9' 6"
Width	mm/ft in	2315/ 7' 7"
Weight	kg/lb	3500/7,720

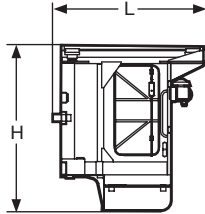

Cab Elevation

L Length	mm/ft in	2415/7'11"
H Height	mm/ft in	2550/8' 4"
Width	mm/ft in	2550/8' 4"
Weight	kg/lb	3500/7,720

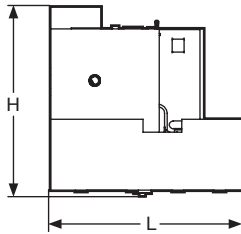

Fuel Tank

L Length	mm/ft in	2970/9'9"
H Height	mm/ft in	2930/9'7"
Width	mm/ft in	2130/7'
Weight	kg/lb	3700/8,160

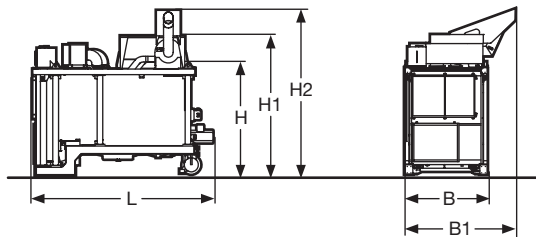

Powerplant

L Length	mm/ft in	4800/15' 9"
H Height	mm/ft in	3000/ 9'10"
H1 Height	mm/ft in	3700/12' 2"
H2 Height	mm/ft in	4400/14' 5"
B Width	mm/ft in	2200/ 7' 3"
B1 Width	mm/ft in	2950/ 9' 8"
Weight	kg/lb	17500/38,580

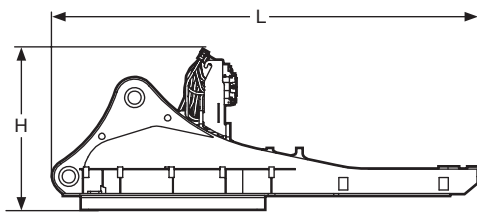

Rotation Deck (with swing ring, swing gears, control valve bracket and service flap)

L Length	mm/ft in	8100/26'7"
H Height	mm/ft in	3882/12'8"
Width	mm/ft in	3700/12'2"
Weight	kg/lb	42700/94,140

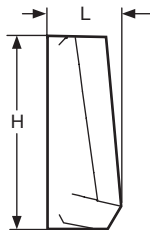

Counterweight

L Length	mm/ft in	1100/ 3'7"
H Height	mm/ft in	3250/10'8"
Width	mm/ft in	6000/19'8"
Weight	kg/lb	25320/55,820

Component Dimensions and Weights

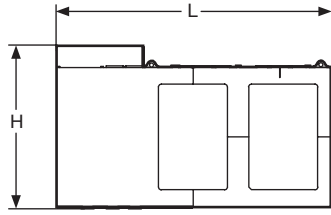

Hydraulic Tank

L Length	mm/ft in	4920/16'2"
H Height	mm/ft in	2900/ 9'6"
Width	mm/ft in	1820/ 6'
Weight	kg/lb	7870/17,350

Hydraulic Oil

Weight	kg/lb	2940/6,500
--------	-------	------------

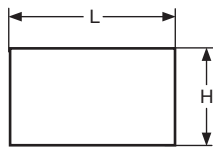

Small Pieces

L Length	mm/ft in	4500/14'9"
H Height	mm/ft in	2600/ 8'6"
Width	mm/ft in	2000/ 6'7"
Weight	kg/lb	4500/9,920

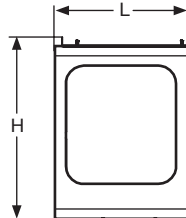

Catwalk Box Left

L Length	mm/ft in	2140/7'
H Height	mm/ft in	2960/9'9"
Width	mm/ft in	700/2'4"
Weight	kg/lb	1900/4,190

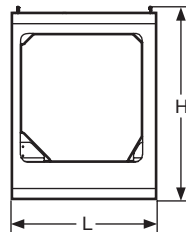

Catwalk Box Right

L Length	mm/ft in	2120/6'11"
H Height	mm/ft in	2960/9' 9"
Width	mm/ft in	950/3' 1"
Weight	kg/lb	800/1,760

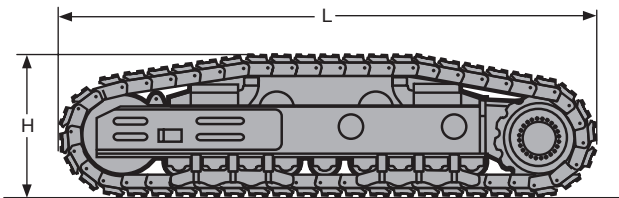

Side Frame (two)

L Length	mm/ft in	8334/27' 4"
H Height	mm/ft in	2360/ 7' 9"
Width over travel drive	mm/ft in	2055/ 6' 9"
Width without travel drive	mm/ft in	1485/ 4'10"
Weight	kg/lb	2 x 43350/2 x 95,570

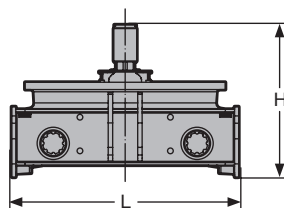

Undercarriage Central Girder

L Length	mm/ft in	3670/12'
H Height	mm/ft in	2482/ 8'2"
Width	mm/ft in	3670/ 8'9"
Weight	kg/lb	25600/56,440

Component Dimensions and Weights

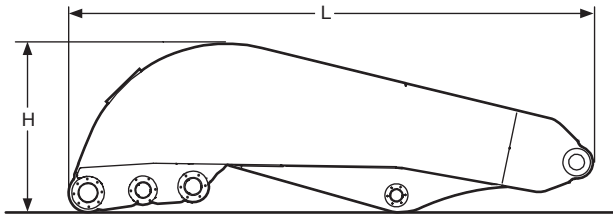

Shovel Boom

L Length	mm/ft in	7250/23' 9"
H Height	mm/ft in	2350/ 7' 9"
Width	mm/ft in	2400/ 7'10"
Weight	kg/lb	25200/55,560

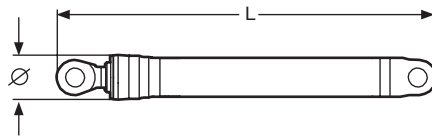

Hoist Cylinder (two) for Shovel Attachment

L Length	mm/ft in	4690/15' 5"
Ø Diameter	mm/in	550/ 22"
Weight	kg/lb	2 x 3510/2 x 7,700

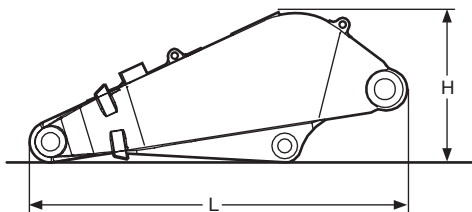

Shovel Stick

L Length	mm/ft in	4700/15'5"
H Height	mm/ft in	1900/ 6'3"
Width	mm/ft in	2250/ 7'5"
Weight	kg/lb	12750/28,110

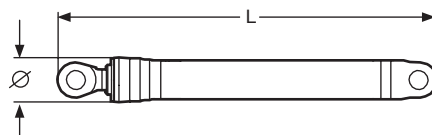

Crowd Cylinder (two)

L Length	mm/ft in	3350/11' 0"
Ø Diameter	mm/in	400/ 15"
Weight	kg/lb	2 x 1470/2 x 3,240

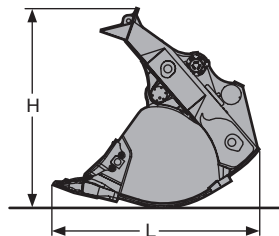

Bottom Dump Bucket

		15,30 m ³ / 20.0 yd ³	17,00 m ³ / 22.2 yd ³	18,00 m ³ / 23.5 yd ³
L Length	mm/ft in	3700/12'2"	3900/12'10"	4200/13'9"
H Height	mm/ft in	3800/12'6"	3800/12' 6"	3800/12'6"
Width	mm/ft in	4200/13'9"	4200/13' 9"	4200/13'9"
Weight	kg/lb	30000/66,000	31000/68,340	31500/69,450

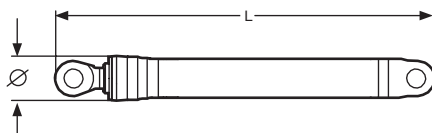

Bucket Tilt Cylinder (two)

L Length	mm/ft in	3950/13' 0"
Ø Diameter	mm/in	450/ 18"
Weight	kg/lb	2 x 2015/2 x 4,440

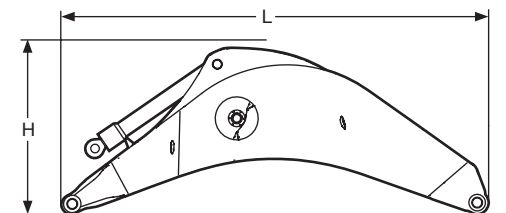

Gooseneck Boom with Stick Cylinders

L Length	mm/ft in	9800/32' 2"
H Height	mm/ft in	3900/12'10"
Width	mm/ft in	2200/ 7' 3"
Weight	kg/lb	30700/67,682

Component Dimensions and Weights

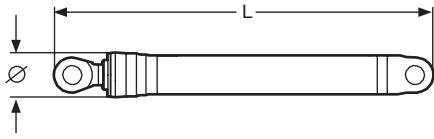

Hoist Cylinders (two) for Backhoe Attachment

L Length	mm/ft in	4680/15' 4"
Ø Diameter	mm/in	550/ 22"
Weight	kg/lb	2 x 3800/2 x 8,380

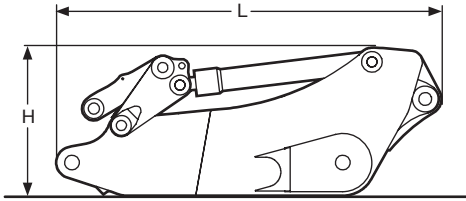

Stick with Bucket Cylinders

L Length	mm/ft in	6000/19' 8"
H Height	mm/ft in	2400/ 7'10"
Width	mm/ft in	1750/ 5' 9"
Weight	kg/lb	18940/41,670

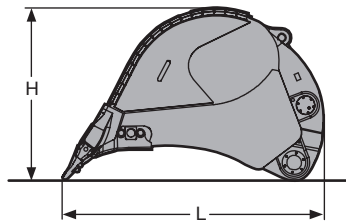

Backhoe Bucket

	15,30 m³/ 20.0 yd³	17,00 m³/ 22.2 yd³	18,00 m³/ 23.5 yd³
--	-----------------------	-----------------------	-----------------------

L Length	mm/ft in	4000/13' 1"	4000/13'1"	4200/13'9"
H Height	mm/ft in	2700/ 8'10"	2800/ 9'2"	2800/ 9'2"
Width	mm/ft in	3500/11' 6"	3500/11'6"	3500/11'6"
Weight	kg/lb	17000/37,480	17790/39,220	18155/40,020

Liebherr-France SAS

2, avenue Joseph Rey, B.P. 90287, F-68005 Colmar Cedex

+33 389 21 30 30, Fax +33 389 21 37 93

www.liebherr.com, E-Mail: info.lfr@liebherr.com