

DIESEL ENGINE

Manufacturer & type	Deutz-BF6M 1013 EC
Design	6-cylinder turbocharged
Engine output	190HP (142 kW)
Nominal speed	2,000 rpm
Displacement	436 cb in (7.2 l)
Cooling system	Water and charge air cooling.
Emission standards	COM II/TIER II
Air filter design	Two-stage filter with safety valve.
Fuel tank	92 US gal (350 l)

ELECTRICAL SYSTEM

Operating voltage	24 V
Batteries	2 x 12 V / 100 Ah
Option	generator system 13/20 kW

TRAVEL DRIVE

<ul style="list-style-type: none"> Hydrostatic drive through transfer gear with two infinitely variable axial piston motors and directly mounted travel brake valves. 	
Travel speed	0 - 12mp/h (20 km/h)
Turning radius	27" (8.2 m)

OPERATING WEIGHTS

Basic machine including work equipment	
With dipperstick (reach 41"/12.5 m with cactus grab)	68,680 lbs (31.150 kg)
With scrap shear GXP 400 R	73,640 lbs (33.400 kg)

SWING SYSTEM

Ring gear	Internally toothed ring gear.
Drive	Multi-stage planetary gear with integrated multi-disc brake.
Uppercarriage swing speed	0 - 8 rpm

UNDERCARRIAGE

<ul style="list-style-type: none"> Front axle: Rigid mounted steering axle for safe transport of loads, max. steering angle 27°. Rear axle: Oscillating rear axle with oscillating axle lock. 	
Stabilizers	4-point stabilizers
Tires	Solid rubber, elastic tires 8-fold 12.00-20

BRAKES

Service brake	Hydraulic single-circuit braking system acting on all four wheel pairs.
Parking brake	Hydraulic disc brake on gear box, acting on both front and rear axle through the propeller shaft.

HYDRAULIC SYSTEM

<ul style="list-style-type: none"> Single-circuit hydraulic system with load-sensing and flow-on-demand-controls; optimum use of the available engine output through load sensing control. Separate oil cooler with large cooling surface. Hydraulic oil filters: Filter elements incorporated in oil tank. Central greasing system as standard. 	
Max. pump capacity	153.2 US gal/min (at 2,000 rpm) (580 l/min)
Max. operating pressure	5220 psi (360 bar)
Hydraulic oil tank	100 US gal (380 l)



WORKING DIAGRAM

MHL 350 FQC, FUCHS QUICK CONNECT quick-attach system: reach 37" (11.3 m) / 41" (12.5 m)

- Work equipment: box-type boom 19" (5.9 m), dipperstick 16" (4.8 m) or 20" (6.1 m) and cactus grab.

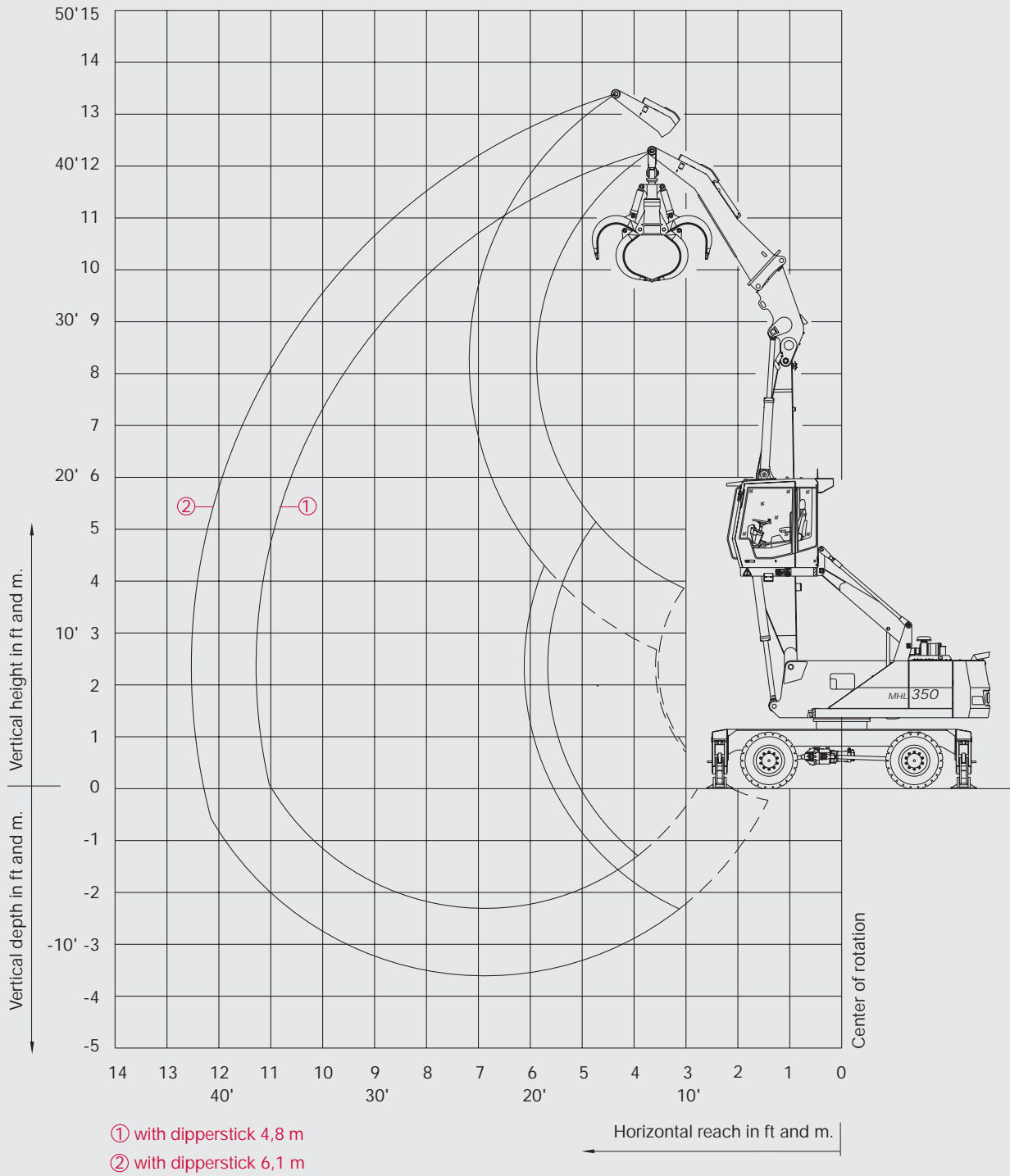



LIFTING CAPACITY

MHL 350 FQC, FUCHS QUICK CONNECT quick-attach system: reach 37" (11.3 m)

- Work equipment: box-type boom 19" (5.9 m), dipperstick 16" (4.8 m) and cactus grab.

Height in ft.	Undercarriage stabilizers	Reach in ft.					
		10	15	20	25	30	35
35	non supported			(18,300*)			
	4-pt. supported			18,300* (18,300*)			
30	non supported			(16,800*)	(12,800)		
	4-pt. supported			16,800* (16,800*)	15,400* (15,400*)		
25	non supported			(16,500*)	(12,800)	(9,000)	
	4-pt. supported			16,500* (16,500*)	15,200* (15,200*)	14,100* (14,100*)	
20	non supported			(17,600*)	(12,600)	(9,000)	(6,600)
	4-pt. supported			17,600* (17,600*)	15,700* (15,700*)	13,900 (14,100*)	10,600 (11,900*)
15	non supported		(24,500*)	(17,200)	(11,900)	(8,600)	(6,600)
	4-pt. supported		24,500* (24,500*)	19,800* (19,800*)	16,800* (16,800*)	13,700 (14,900*)	10,400 (13,200*)
10	non supported		(25,100)	(15,900)	(11,200)	(8,400)	(6,400)
	4-pt. supported		31,300* (31,300*)	22,700* (22,700*)	17,600 (18,300*)	13,000 (15,400*)	10,100 (13,000)
5	non supported		(22,000)	(14,600)	(10,400)	(7,900)	(6,200)
	4-pt. supported		37,000* (37,000*)	23,800 (25,400*)	16,800 (19,600*)	12,600 (15,900*)	9,900 (12,800*)
0	non supported	(11,000*)	(20,500)	(13,400)	(9,900)	(7,500)	(6,000)
	4-pt. supported	11,000 (11,000*)	30,900* (30,900*)	22,700 (26,700*)	16,100 (20,300*)	12,300 (15,900)	9,900 (12,800*)
-5	non supported		(20,100)	(13,000)	(9,500)	(7,300)	
	4-pt. supported		29,300* (29,300*)	22,300 (26,000*)	15,900 (19,600*)	12,100 (15,200*)	

Height in m	Undercarriage stabilizers	Reach in m					
		3	4.5	6	7.5	9	10.5
10.5	non supported			(8.3*)			
	4-pt. supported			8.3* (8.3*)			
9	non supported			(7.6*)	(5.8)		
	4-pt. supported			7.6* (7.6*)	7.0* (7.0*)		
7.5	non supported			(7.5*)	(5.8)	(4.1)	
	4-pt. supported			7.5* (7.5*)	6.9* (6.9*)	6.4* (6.4*)	
6	non supported			(8.0*)	(5.7)	(4.1)	(3.0)
	4-pt. supported			8.0* (8.0*)	7.1* (7.1*)	6.3 (6.4*)	4.8 (5.4*)
4.5	non supported		(11.1*)	(7.8)	(5.4)	(3.9)	(3.0)
	4-pt. supported		11.1* (11.1*)	9.0* (9.0*)	7.6* (7.6*)	6.2 (6.7*)	4.7 (6.0*)
3	non supported		(11.4)	(7.2)	(5.1)	(3.8)	(2.9)
	4-pt. supported		14.2* (14.2*)	10.3* (10.3*)	8.0 (8.3*)	5.9 (7.0*)	4.6 (5.9)
1.5	non supported		(10.0)	(6.6)	(4.7)	(3.6)	(2.8)
	4-pt. supported		16.8* (16.8*)	10.8 (11.5*)	7.6 (8.9*)	5.7 (7.2*)	4.5 (5.8)
0	non supported	(5.0)	(9.3)	(6.1)	(4.5)	(3.4)	(2.7)
	4-pt. supported	5.0* (5.0*)	14.0* (14.0*)	10.3 (12.1*)	7.3 (9.2*)	5.6 (7.2)	4.5 (5.8)
-1.5	non supported		(9.1)	(5.9)	(4.3)	(3.3)	
	4-pt. supported		13.3* (13.3*)	10.1 (11.8*)	7.2 (8.9*)	5.5 (6.9*)	

The values stated in the table apply to working envelope ① (including dipperstick 4.8 m) on page 2.

REMARKS

The values are stated in lbs or tons (t). The pump pressure for this table is 5220 psi (360 bar). The values amount to 75 % of the static tipping load or 87 % of the hydraulic lifting force (marked *), in accordance with ISO 10567. When the machine is standing on solid and level ground, these values apply to slewing operations through 360°. The values in brackets apply in the lengthwise direction of the undercarriage, oscillating axle locked. The "unsupported" values apply only when the load

is hoisted above the front or rear axle.

The weight of the attached load hoisting implement (grab, magnet, load hook etc.) must be deducted from the carrying capacity values. The weight of the fast changing device is containing in the carrying capacity table.



LIFTING CAPACITY

MHL 350 FQC, FUCHS QUICK CONNECT quick-attach system: reach 41" (12.5 m)

- Work equipment: box-type boom 19" (5.9 m), dipperstick 20" (6.1 m) and cactus grab.

Height in ft.	Undercarriage stabilizers	Reach in ft.						
		10	15	20	25	30	35	40
40	non supported			(16,800*)				
	4-pt. supported			16,800* (16,800*)				
35	non supported				(13,700)	(9,700)		
	4-pt. supported				13,900* (13,900*)	10,600* (10,600*)		
30	non supported				(13,000*)	(9,900)		
	4-pt. supported				13,000* (13,000*)	12,600* (12,600*)		
25	non supported				(12,800*)	(9,900)	(7,300)	
	4-pt. supported				12,800* (12,800*)	12,300* (12,300*)	11,200 (11,900*)	
20	non supported				(13,400*)	(9,700)	(7,300)	
	4-pt. supported				13,400* (13,400*)	12,800* (12,800*)	11,200 (11,900*)	
15	non supported			(16,100*)	(13,000)	(9,500)	(7,100)	(5,500)
	4-pt. supported			16,100* (16,100*)	14,800* (14,800*)	13,400* (13,400*)	11,000 (12,300*)	8,600 (10,800)
10	non supported		(24,000*)	(17,400)	(12,100)	(8,800)	(6,800)	(5,300)
	4-pt. supported		24,000* (24,000*)	19,400* (19,400*)	16,500* (16,500*)	13,900 (14,300*)	10,800 (12,800*)	8,600 (10,800)
5	non supported		(24,700)	(15,900)	(11,200)	(8,400)	(6,600)	(5,100)
	4-pt. supported		32,200* (32,200*)	22,900* (22,900*)	17,600 (18,300*)	13,200 (15,200*)	10,400 (13,200*)	8,400 (10,800)
0	non supported	(13,700*)	(21,800)	(14,300)	(10,400)	(7,900)	(6,200)	(5,100)
	4-pt. supported	13,700* (13,700*)	37,500* (37,500*)	23,600 (25,800*)	16,800 (19,600*)	12,800 (16,100*)	10,100 (13,000)	8,200 (10,600)
-5	non supported	(14,800*)	(20,300)	(13,400)	(9,900)	(7,500)	(6,000)	
	4-pt. supported	14,800* (14,800*)	32,800* (32,800*)	22,500 (26,700*)	16,100 (20,300*)	12,300 (16,100*)	9,900 (12,800)	
-10	non supported		(19,800)	(13,000)	(9,500)	(7,500)		
	4-pt. supported		30,900* (30,900*)	22,000 (25,800*)	15,900 (19,400*)	12,100 (15,200*)		

Height in m	Undercarriage stabilizers	Reach in m						
		3	4.5	6	7.5	9	10.5	12
12	non supported			(7.6*)				
	4-pt. supported			7.6* (7.6*)				
10.5	non supported				(6.2)	(4.4)		
	4-pt. supported				6.3* (6.3*)	4.8* (4.8*)		
9	non supported				(5.9*)	(4.5)		
	4-pt. supported				5.9* (5.9*)	5.7* (5.7*)		
7.5	non supported				(5.8*)	(4.5)	(3.3)	
	4-pt. supported				5.8* (5.8*)	5.6* (5.6*)	5.1 (5.4*)	
6	non supported				(6.1*)	(4.4)	(3.3)	
	4-pt. supported				6.1* (6.1*)	5.8* (5.8*)	5.1 (5.4*)	
4.5	non supported			(7.3*)	(5.9)	(4.3)	(3.2)	(2.5)
	4-pt. supported			7.3* (7.3*)	6.7* (6.7*)	6.1* (6.1*)	5.0 (5.6*)	3.9 (4.9*)
3	non supported		(10.9*)	(7.9)	(5.5)	(4.0)	(3.1)	(2.4)
	4-pt. supported		10.9* (10.9*)	8.8* (8.8*)	7.5* (7.5*)	6.3 (6.5*)	4.9 (5.8*)	3.9 (4.9)
1.5	non supported		(11.2)	(7.2)	(5.1)	(3.8)	(3.0)	(2.3)
	4-pt. supported		14.6* (14.6*)	10.4* (10.4*)	8.0 (8.3*)	6.0 (6.9*)	4.7 (6.0*)	3.8 (4.9)
0	non supported	(6.2*)	(9.9)	(6.5)	(4.7)	(3.6)	(2.8)	(2.3)
	4-pt. supported	6.2* (6.2*)	17.0* (17.0*)	10.7 (11.7*)	7.6 (8.9*)	5.8 (7.3*)	4.6 (5.9)	3.7 (4.8)
-1.5	non supported	(6.7*)	(9.2)	(6.1)	(4.5)	(3.4)	(2.7)	
	4-pt. supported	6.7* (6.7*)	14.9* (14.9*)	10.2 (12.1*)	7.3 (9.2*)	5.6 (7.3*)	4.5 (5.8)	
-3	non supported		(9.0)	(5.9)	(4.3)	(3.4)		
	4-pt. supported		14.0* (14.0*)	10.0 (11.7*)	7.2 (8.8*)	5.5 (6.9*)		

The values stated in the table apply to working envelope ② (including dipperstick 6.1 m) on page 2.

■ For additional remarks see notes on page 3.

WORKING DIAGRAM

MHL 350 FQC, FUCHS QUICK CONNECT quick-attach system
 • Work equipment: box-type boom 19" (5.9 m), Genesis shears GXP 400 R.

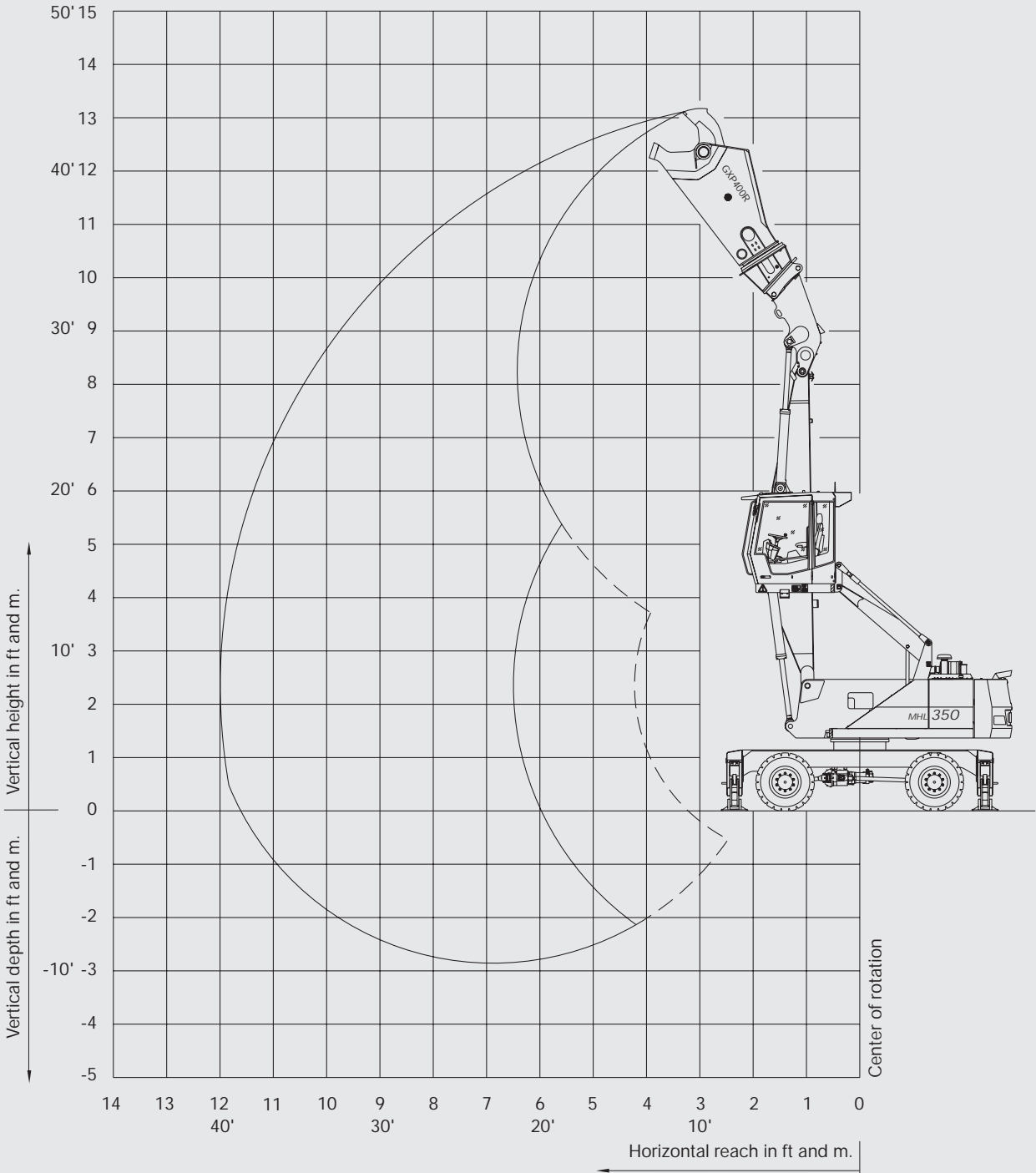

WARNING

Due to the danger of tilting the shears are only to be taken up and laid down with the chassis in longitudinal direction. With the shears attached, the superstructure may only be slewed if the machine is adequately supported. The shears are only

to be operated if the machine is adequately supported (outriggers down). The dipperstick, multi-purpose stick, and shears are only to be laid down in a suitable and stable device designed for this purpose.



WORKING DIAGRAM

MHL 350 FQC, FUCHS QUICK CONNECT quick-attach system: reach 39" (12.0 m)

- Work equipment: box-type boom 19" (5.9 m), multi-purpose stick 18" (5.6 m) and sorting grab.

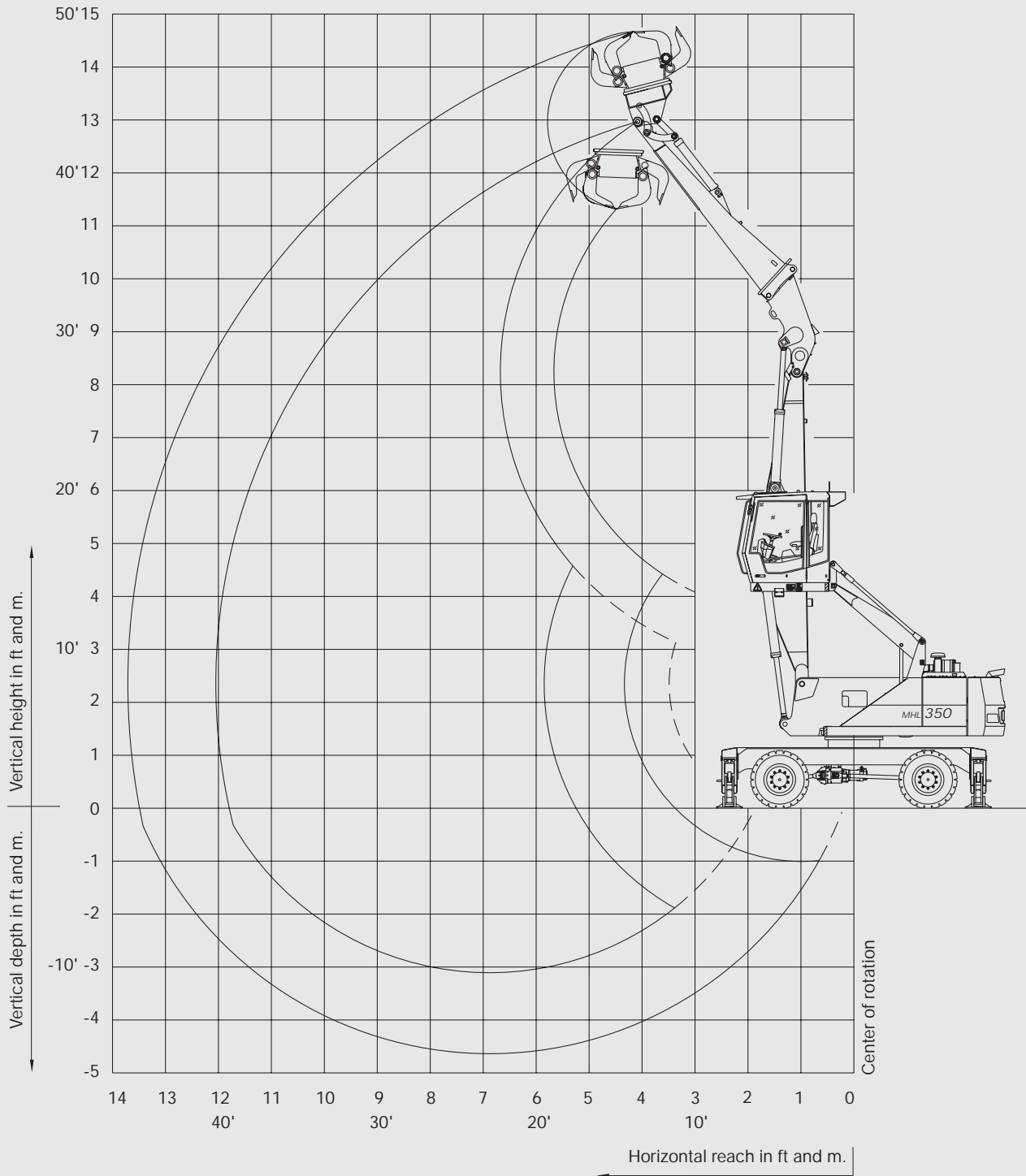



LIFTING CAPACITY

MHL 350 FQC, FUCHS QUICK CONNECT quick-attach system: reach 39" (12.0 m)

- Work equipment: box-type boom 19" (5.9 m), multi-purpose stick 18" (5.6 m) and sorting grab.

Height in ft.	Undercarriage stabilizers	Reach in ft.						
		10	15	20	25	30	35	40
40	non supported			(15,200*)				
	4-pt. supported			15,200* (15,200*)				
35	non supported				(13,000)			
	4-pt. supported				14,800* (14,800*)			
30	non supported				(13,200)	(9,500)		
	4-pt. supported				13,700* (13,700*)	13,200* (13,200*)		
25	non supported				(13,200)	(9,500)	(7,100)	
	4-pt. supported				13,400* (13,400*)	12,800* (12,800*)	10,800 (11,000*)	
20	non supported				(13,000)	(9,300)	(6,800)	
	4-pt. supported				14,100* (14,100*)	13,000* (13,000*)	10,800 (12,300*)	
15	non supported			(17,400*)	(12,300)	(9,000)	(6,800)	
	4-pt. supported			17,400* (17,400*)	15,400* (15,400*)	13,700* (13,700*)	10,600 (12,600*)	
10	non supported		(26,900*)	(16,800)	(11,700)	(8,600)	(6,600)	(5,100)
	4-pt. supported		26,900* (26,900*)	20,700* (20,700*)	17,000* (17,000*)	13,400 (14,600*)	10,400 (12,800*)	8,400 (9,300*)
5	non supported		(23,600)	(15,200)	(10,800)	(8,200)	(6,200)	(5,100)
	4-pt. supported		34,400* (34,400*)	24,000* (24,000*)	17,200 (18,700*)	12,800 (15,400*)	10,100 (13,000*)	8,200 (9,700*)
0	non supported	(11,900*)	(21,400)	(13,900)	(10,100)	(7,700)	(6,000)	
	4-pt. supported	11,900* (11,900*)	37,700 (37,600*)	23,100 (26,200*)	16,300 (19,800*)	12,300 (16,100*)	9,900 (12,800)	
-5	non supported	(14,600*)	(20,300)	(13,200)	(9,700)	(7,500)	(6,000)	
	4-pt. supported	14,600* (14,600*)	30,400* (30,400*)	22,500 (26,700*)	19,900 (20,100*)	12,100 (15,900*)	9,700 (12,600)	
-10	non supported			(13,000)	(9,500)			
	4-pt. supported			22,000 (24,900*)	15,700 (18,700*)			

Height in m	Undercarriage stabilizers	Reach in m						
		3	4.5	6	7.5	9	10.5	12
12	non supported			(6.9*)				
	4-pt. supported			6.9* (6.9*)				
10.5	non supported				(5.9)			
	4-pt. supported				6.7* (6.7*)			
9	non supported				(6.0*)	(4.3)		
	4-pt. supported				6.2* (6.2*)	6.0* (6.0*)		
7.5	non supported				(6.0*)	(4.3)	(3.2)	
	4-pt. supported				6.1* (6.1*)	5.8* (5.8*)	4.9 (5.0*)	
6	non supported				(5.9)	(4.2)	(3.1)	
	4-pt. supported				6.4* (6.4*)	5.9* (5.9*)	4.9 (5.6*)	
4.5	non supported			(7.9*)	(5.6)	(4.1)	(3.1)	
	4-pt. supported			7.9* (7.9*)	7.0* (7.0*)	6.2* (6.2*)	4.8 (5.7*)	
3	non supported		(12.2*)	(7.6)	(5.3)	(3.9)	(3.0)	(2.3)
	4-pt. supported		12.2* (12.2*)	9.4* (9.4*)	7.7* (7.7*)	6.1 (6.6*)	4.7 (5.8*)	3.8 (4.2*)
1.5	non supported		(10.7)	(6.9)	(4.9)	(3.7)	(2.8)	(2.3)
	4-pt. supported		15.6* (15.6*)	10.9* (10.9*)	7.8 (8.5*)	5.8 (7.0*)	4.6 (5.9)	3.7 (4.4*)
0	non supported	(5.4*)	(9.7)	(6.3)	(4.6)	(3.5)	(2.7)	
	4-pt. supported	5.4* (5.4*)	17.1 (17.5*)	10.5 (11.9*)	7.4 (9.0*)	5.6 (7.3*)	4.5 (5.8)	
-1.5	non supported	(6.6*)	(9.2)	(6.0)	(4.4)	(3.4)	(2.7)	
	4-pt. supported	6.6* (6.6*)	13.8* (13.8*)	10.2 (12.1*)	7.2 (9.1*)	5.5 (7.2*)	4.4 (5.7*)	
-3	non supported			(5.9)	(4.3)			
	4-pt. supported			10.0 (11.3*)	7.1 (8.5*)			

■ For additional remarks see notes on page 3.

CAB

- Hydraulically height-adjustable cab with max. eye level of 18.4"/5.6 m, human-engineered, functional design and excellent all-round visibility.
- Air-cushioned comfort seat with pneumatically adjustable lumbar support, safety belt and headrest. Seat heating available on request. The seat meets EC-safety and health requirements (Directive 89/392/EEC, Paragraph 3.2.2). Seat position, seat inclination and seat cushion multi-adjustable in line with position of armrests and pilot control units.
- 3-setting fan for hot water heating, 4 adjustable defroster nozzles.
- Tilt and height-adjustable steering column; front windshield slideable under cab roof, with pull-down sunblind; lift-up skylight on cab roof.
- Air conditioning as standard.
- Options: engine-independent heating, bulletproof glass, cab stone guard, stereo cassette radio.
- Sound power level (guaranteed) LW(A) = 107 dB(A).

SCRAP SHEARS

Type	Genesis GXP 400 R (rotatable)
Cutting force	980 US tons (903 t)
Weight	10,582 lbs (4.8 t)
Feed opening	28" / 711 mm
Standard length	142" / 3.597 m

OFFICIAL HOMOLOGATION

- Certification according to CE regulations.

Transport dimensions on flat-bed trailer

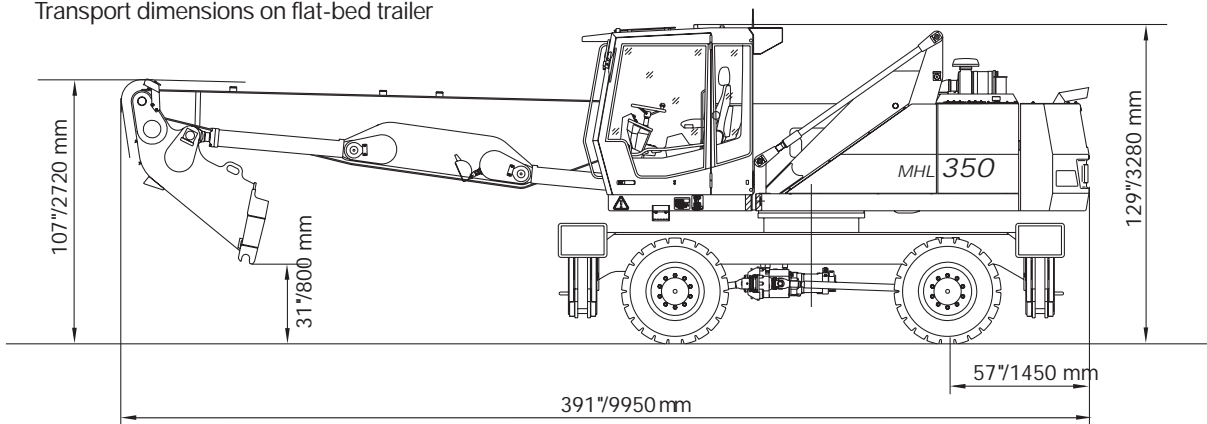

TEREX Fuchs

8800 Rostin Road
Southaven, MS 38671
USA

TOLL FREE: 1-888-201-6008
PHONE: 662-393-1800
FAX: 662-393-1700
WEB www.terex.com
EMAIL fuchs@fuchsus.com